

MA-2-XS-G Monitor Arm

COMPLETED ASSEMBLY



Loading up to 44 lbs / 20 kg

STEP 1 Join the Arm Components Together

Use the hardware supplied to attach together the following components:

- LA-511 Vesa (2)
- LA-512 Arm (2)
- LA-515 Double Connector

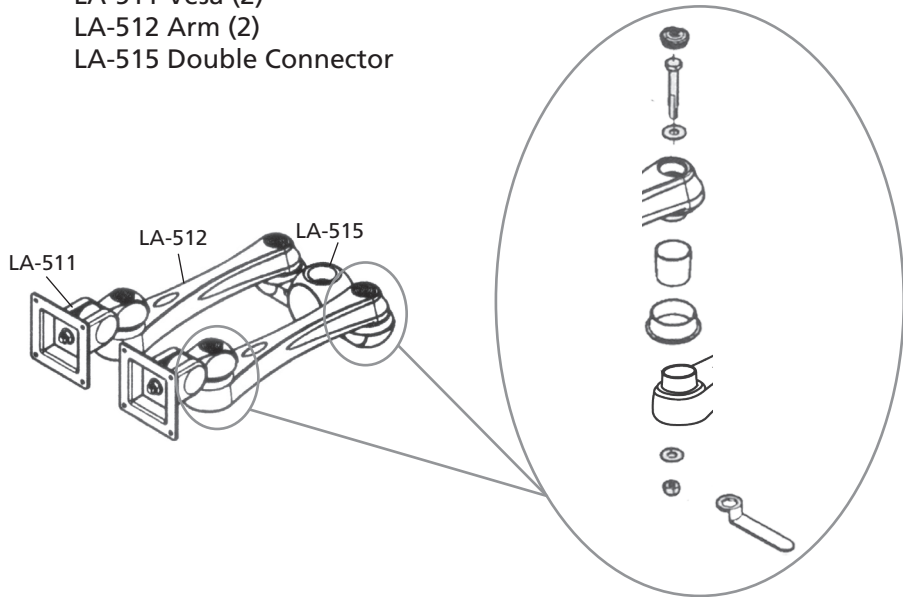

Assembly Guide

STEP 2 Mount the Grommet to the Worksurface

Use the hardware supplied to attach the LA-502A grommet to the work-surface. Then attach the LA-501A pole to the LA-502A grommet.

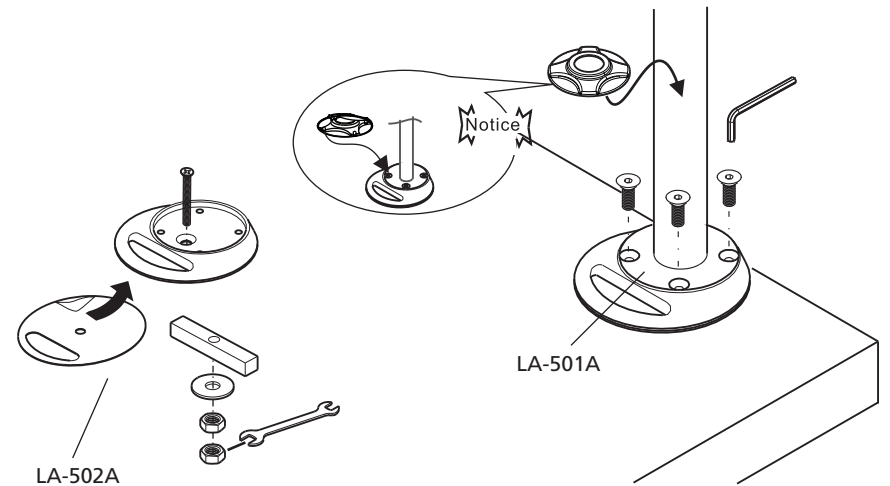

STEP 3 Mount the Monitor Arm to the Monitor

Place monitor face down on a flat surface. Place LA-511 Vesa on the back of the monitor and secure with screws supplied.

75mmx75mm VESA interface.

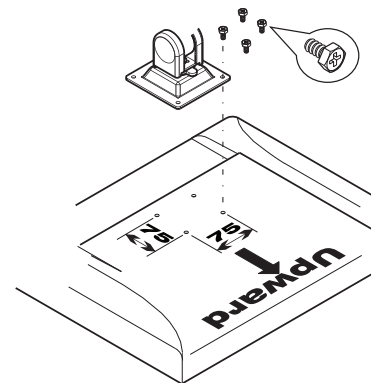

100mmx100mm VESA interface.

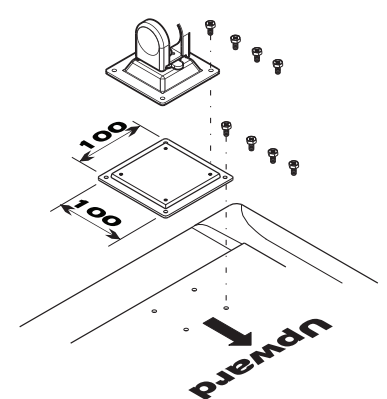

Assembly Guide

STEP 4 → Mount the Monitor Arm to the Pole

Loosen the two screws slightly on the LA-515 connector. Carefully support the monitors and place the arm onto the pole. Adjust the arm to the desired viewing height. Tighten up the screws. Insert pole cap into pole.

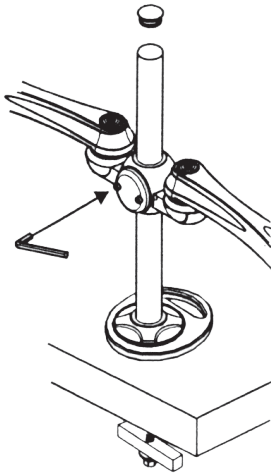

STEP 5 → Adjusting Swivel Tension

Use the wrench to tighten or loosen the arm. Screw on the cable holder.

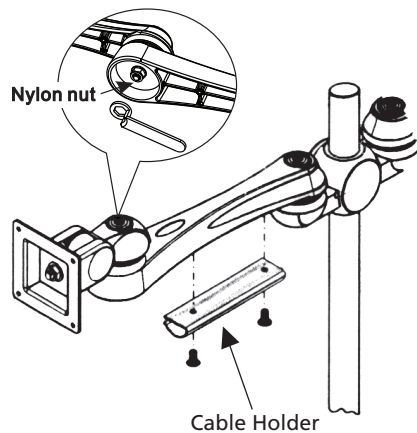

3

Assembly Guide

STEP 6 → Adjusting Vesa Tension

When assembling the arm with monitors of differing weights, you may find that the tension of the vesa needs to be adjusted to maintain the desired monitor position. If so, adjust as follows:

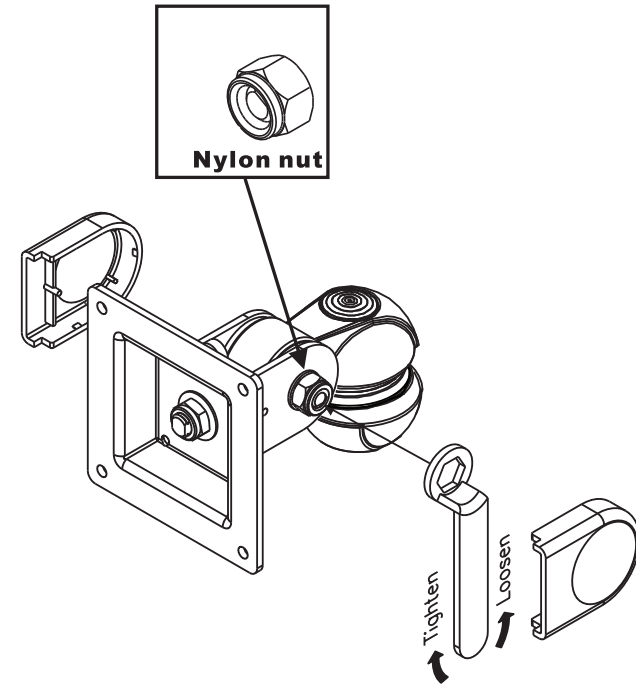

- Remove the two plastic vesa joint covers
- Find the nylon nut (not the screw head) and use the included wrench to adjust the tension.
- Use one hand to support the monitor and adjust the tension of the vesa.
 - Clockwise: more tension
 - Counterclockwise: less tension
- When the desired tension is achieved, replace the two plastic covers.

Caution:

- Support the monitor during the adjustment procedure.
- Only adjust the nylon nut (not the screw head).
- Do not disassemble the vesa.

4

MA-2-XS-G