

SHIFT

SHIFT INSTALLATION INSTRUCTIONS

IN-base|
2 parallel leg

Applicable bases:

- SB-IN-2-XXXX

Parts List:

1.	1X	SB-IN-LAR _____	Leg – Right
2.	1X	SB-IN-LAL _____	Leg – Left
3.	2X	SB-E5-FOOT24 _____	Feet
4.	1X	SB-E5-CRCH-XX _____	Cross Member Assembly (Channel / Cover)
5.	4X	Foot Screws (3/8-16 Hex Head)	
6.	4X	Cross Member Nut (1/4-20 Accorn)	
7.	16X	Work Surface Screw (#10 Quad Pan Head Wood Screw)	
8.	4X	Cable Clip Screw (#8 Phillips Pan Head Wood Screw)	

Component features:

- Strong 11GA steel construction.
- Height adjustable – increment system .

Assembly time (approx.):

- 8-15 minutes.

Tool(s) required:

- 7/16" crescent wrench
- 9/16 " crescent wrench
- #2 Philips screw driver

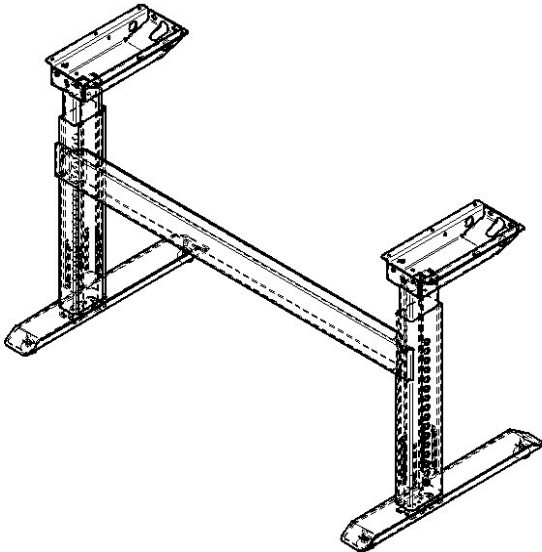

SHIFT

-1-
Using 2 - 3/8" dia x 1.25" - screws fasten
foot to leg.

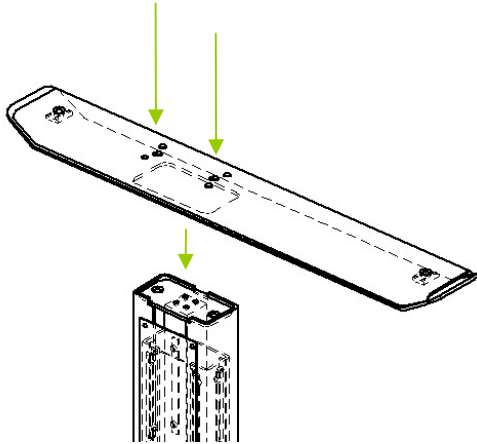

-2-
Using 2 - 1/4" dia x .5" - screws fasten cross
channel to leg.

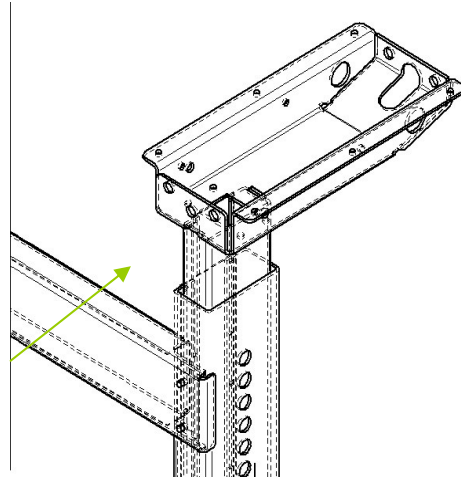

-3-
Using 12 - #10 dia x .75" - screws fasten
worksurface to base assembly.

Push in the pins and adjust table to the desired
height.

