

SA-SW

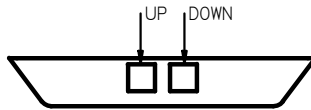
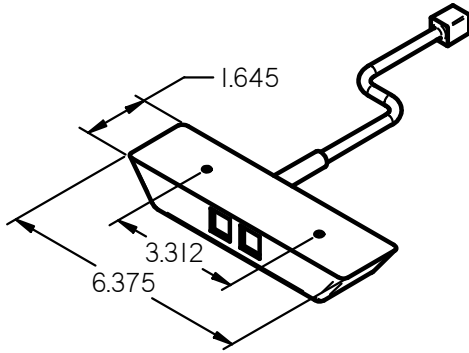

HOW OPERATE:

I) Use the UP or Down button to adjust the table height.

Note: If a power interruption occurs the table will require re-initialization. The heights stored in memory may be lost and will require re-setting.

SA-MSW-0

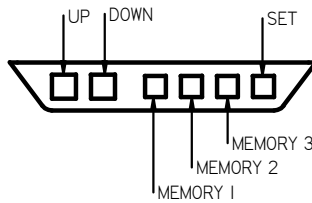
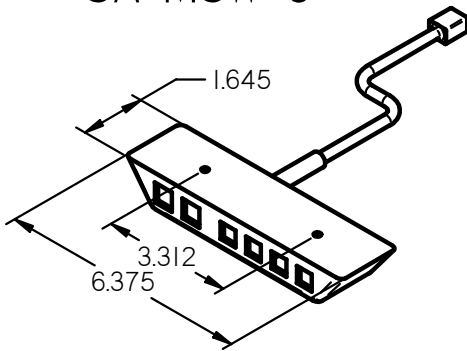

HOW OPERATE:

- I) Use the UP or Down button to adjust the table height
- 2) To set a height into memory:
 - i) Position the table at desired height
 - ii) Press the SET button
 - iii) Press the desire MEMORY button
 - iv) Press the SET button
 - v) Repeat (2) to set remaining memory positions
- 3) To recall a position in memory:
 - i) Press and hold MEMORY button until table comes to a stop

Note: If a power interruption occurs the table will require re-initialization. The heights stored in memory may be lost and will require re-setting.

SA-MSW-R0-0

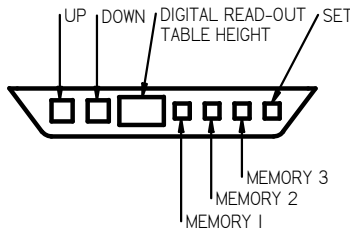
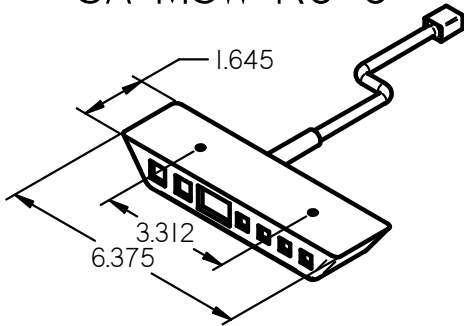

HOW OPERATE:

- I) Use the UP or Down button to adjust the table height
- 2) To set a height into memory:
 - i) Position the table at desired height
 - ii) Press the SET button
 - iii) Press the desire MEMORY button
 - iv) Press the SET button
 - v) Repeat (2) to set remaining memory positions
- 3) To recall a position in memory:
 - i) Press and hold MEMORY button until table comes to a stop

Note: If a power interruption occurs the table will require re-initialization. The heights stored in memory may be lost and will require re-setting.

REV	DETAILS	BY
	UNLESS OTHERWISE SPECIFIED - DIMENSIONS ARE IN INCHES ANGLES = 0.5° - XX = ± 0.1 (1/10) - XXX = ± 0.06 (1/16) - XXXX = ± 0.031 (1/32)	
	DRAWN BY: Erik Keuthen	DATE CREATED (M/D/Y): 3/12/2008
	SCALE: NTS / UNLESS NOTED	DATE MODIFIED (M/D/Y): 7/17/2008
	PART MATERIAL:	SHEET: 1 of 1

ISE
 950 Warden Avenue
 Toronto ON, Canada, M1L4E3
 tel: 416-759-2929
 fax: 416-759-9272
 web: www.ise-ergonomics.com
 email: info@ise-ergo.com

TITLE: SHIFT - E5 AND E6 SWITCH OPTIONS
DRAWING NAME: SA-SW-short
 DRAWING FILE: C:\Documents and Settings\erik\Desktop\Instructions images\SA-SW-short.dft
PART/ASSEMBLY: SA-SW-short.par
 PART FILE: N:\Parts\SB-xxxx\SA-SW\SA-SW-short.par